

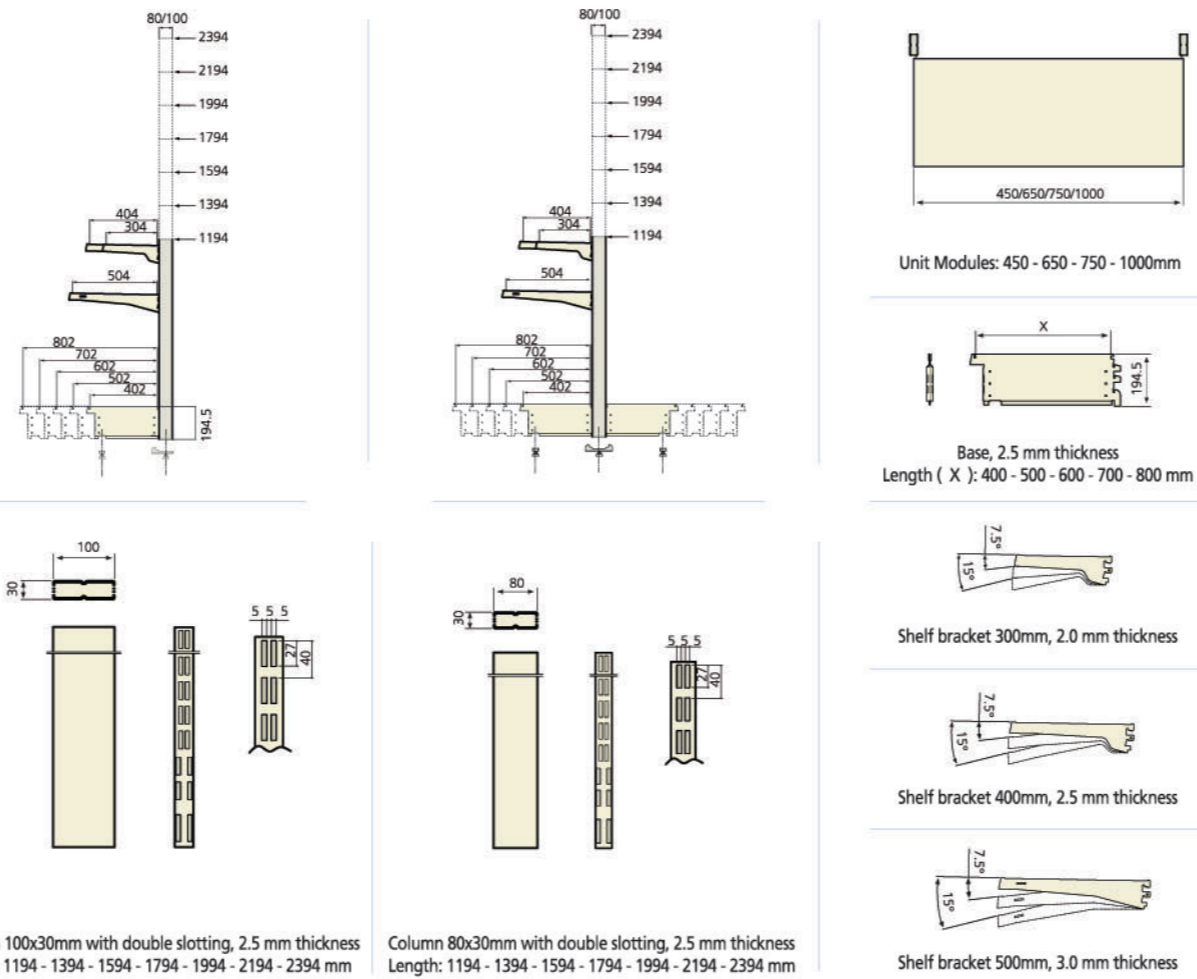

WALL TYPE & ISLAND TYPE SHELVING UNITS



Back panel composition

Full plate back panel (Standard)

Perforated back panel (Optional)

H 2394mm	H 2194mm		H 1994mm		H 1794mm		H 1594mm		H 1394mm		H 1194mm	
200	400	400	400	400	400	400	400	400	400	400	400	400

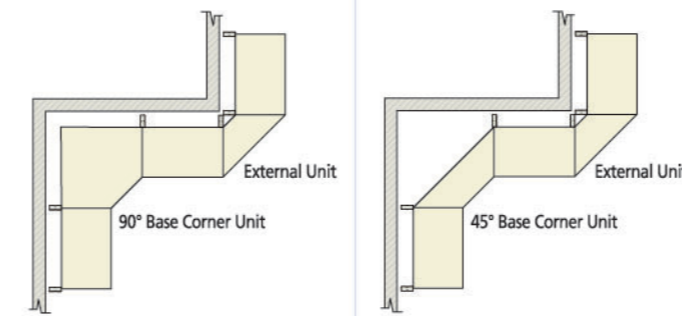

Head Office & Showroom
Bayader Wadi El-Sier, Industrial Str.
P.O.Box: 141399 - Amman 11814 - JORDAN
Tel.: 00962 (06) 5865536/7/8
Fax: 00962 (06) 5863707
E-mail: headoffice@abdin.com.jo
Website: www.abdin.com.jo

Plant
Al- Qastal Area, Airport Road.
P.O.Box: 141399 - Amman 11814 - JORDAN
Tel.: 00962 (06) 4711506/7
Fax: 00962 (06) 4711296
E-mail: plant@abdin.com.jo
Website: www.abdin.com.jo

Distributed by:

Syria Branch
Housh Blas, Zone
Dera'a Highway - Damascus.
Tel.: 00963 (11) 6731323
Fax: 00963 (11) 6731322
E-mail: syria@abdin.com.jo
Website: www.abdin.com.jo



The manufacturer reserves the right to modify any product without prior notice

PREMIUM QUALITY SINCE 1974



وحدات رفوف السوبر ماركت
Supermarket Shelving Units



مؤسسة عابدين الصناعية
ABDIN INDUSTRIAL EST.



وحدات رفوف السوبر ماركت Supermarket Shelving Units

إن تعدد استعمالات نظام الرفوف ووجود العديد من القطع التي يمكن إضافتها له لتناسب الاحتياجات المختلفة بسهل عملية استغلال جميع المساحة المتوفرة للعرض وإبراز المعروضات بصورة جميلة.

The versatility of shelving system combined with a large choice of accessories make it very easy to utilize all the space available in the selling area and display the products in the best attractive way.

